

NEWSLTR

#03 IMPROVING LIVES

PG. 3 BUSINESS NEWS

Upping Skills, Our Values
and Recent Staff Moves

PG. 8 LEGRAND SOLUTIONS

Legrand Services, Lincoo
Data Center PDUs and
Arteir One Module USB
Sockets and Unswitched
Flush Mount Socket

PG. 14 DISTRIBUTORS & RESELLERS

Zambia and Iletco





Johan Bosch
General Manager Legrand South Africa

FROM THE GM'S DESK...

With nearly half of the year already passed, 2023 so far has not only proved itself to be somewhat challenging in terms of the burdens of loadshedding, its effect on the exchange rate, economy and foreign investment, has also been felt.

On the positive side though, it is also proving to be a busy one for us at Legrand South Africa with the implementation of our new Services offering and our on-site technical team to support that. With the flourishing Data Center market, it was a natural development in the evolution of our business to introduce the offering. Coupled of course with Legrand's extensive product solutions for the Data Centre domain and the continual introduction of new products like the new Linkeo PDUs, we now are able to offer you a tailor-made solution for your projects, from planning to installation through to maintenance and after sales.

As we approach the winter months and concern ourselves with how we are going to keep warm without electricity, I wish you all (as the French say) "Bon Courage".

CONTENTS

03 **Upping Skills for Optimum Services**

Legrand South Africa technicians up their game with a visit to the Borri UPS facilities in Italy

04 **Our Values Unite Us**

Intimately linked, our values and our purpose guide us on a daily basis.

06 **Staff Moves**

Its been a time to bid farewell, welcome, and congratulate here at Legrand South Africa.

8 **Services for Your Projects**

Legrand South Africa has entered into a new business model of service level agreements with strategic partners, enabling us to offer direct installation and after sales services.

10 **Linkeo PDUs**

Linkeo Data Center PDUs provide extensive features tailored to the needs of the ever-increasing requirements of data centers.

14 **New 1 MOD Arteor USB Chargers**

Hailing the arrival of the new Arteor™ one module USB chargers.

14 **Iletco Zambia**

For over 25 years, Iletco is a leading distributor of Legrand products in Zambia

The Legrand NEWSLTR publication team would like to thank all the participants:

DIRECTOR OF PUBLICATION: Melanie Vosloo
EDITORIAL STAFF: Melanie Vosloo, Shaun Dobbs, Lindy Morton
LAYOUT: Shaun Dobbs
PHOTOS: Legrand, Shutterstock
All rights reserved © Legrand May 2023



UPPING SKILLS FOR OPTIMUM SERVICES

As part of Legrand's new Services offering, our commitment to providing the best solutions and technical skills means ensuring our technical team is up to date with the latest technology and enabled with the necessary knowhow to advise, install and provide maintenance for your project's electrical infrastructure.



Both Johan Bosch (GM, Southern Africa) and Grant Colling (Senior After Sales Manager Southern Africa) recently attended a global Service Manager Seminar With an aim to improve the services offering and ensure top level customer satisfaction, the seminar addressed important topics like efficiency (MTTR), uptime, accredited service levels, spare part holding and service level agreements.

With South Africa dealing with the burden of continuous load shedding, there is an increase in the number of times backup power equipment is used. This has an effect on the lifespan of the equipment, increasing the risk of equipment failure. As such, while visiting the Borri facilities in Poppi, Italy, specific priority was given to the mitigation of load shedding impacts on equipment as well as updated training on local service repairs, all electronic components, services and FAT & SAT functions applicable to South Africa.



OUR VALUES UNITE US



WE SEIZE THE FUTURE

- By creating tomorrow's buildings today
- By putting sustainability at the core of our growth
- By growing the talents that will manage tomorrow's world



WE EMBRACE INCLUSION

- By respecting others as they are
- By seizing our workforces diversity as an opportunity to be a better business
- By taking our stakeholders diversity as a strength and a driver



WE MOVE IN SYNC

- By continually providing our entire ecosystem
- By providing the best experience for our customers
- By moving forward with brands & partners, driving strategy and a common



#LegrandImprovingLives

OUR VALUES, OUR PURPOSE

Intimately linked, our values and our purpose guide us on a daily basis. We all act to improve lives: this is our purpose. It is based on 5 unifying values that are at the heart of each of our actions and decisions. They look like us and bring us together.

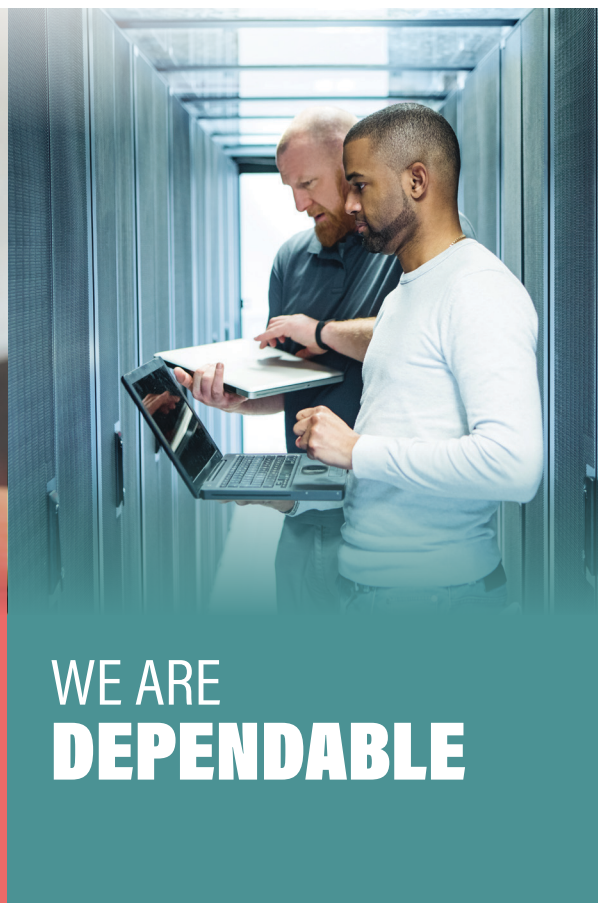

WE STRIVE FOR
SIMPLICITY

WE ARE
DEPENDABLE

g added value to
experience to our
our people,
en by a common
purpose

- By fostering authentic human relationship
- By promoting transparency and honesty in all that we do
- By designing products that are easy to install, use and maintain

- By combining quality and sustainability in the solutions we deliver
- By eliminating our negative impacts and having a positive impact everywhere we can.
- By ensuring responsible business practices and meeting our commitments



BUSINESS NEWS

STAFF

Moves

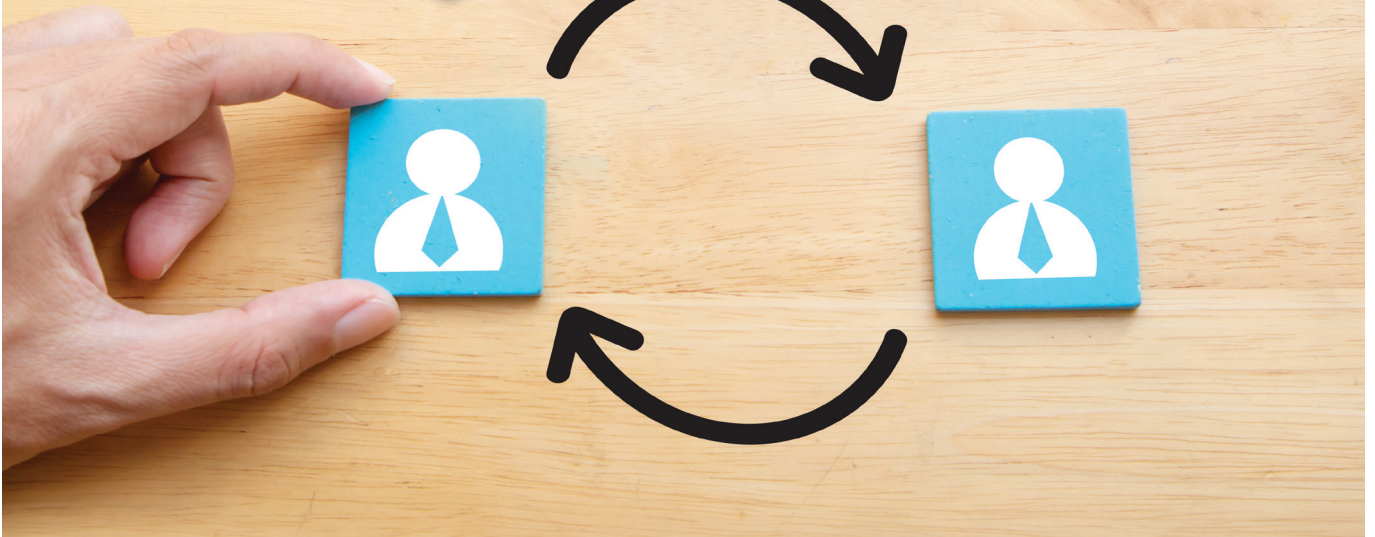

NTHABISENG NTENGO
- HR & COMPLIANCE MANAGER



MELANIE VOSLOO
- MARKETING MANAGER & VP
FOR DIY & WHOLESALE



BARRY JARDIM
- ELIOT COMMERCIAL MANAGER



It's been a time to bid farewell, welcome, and congratulate here at Legrand South Africa.

Firstly, we extend a warm welcome to our new HR & Compliance Manager, Nthabiseng Ntengo. We wish her all the best in her new position here at Legrand.

Melanie Vosloo, who in addition to her role as Marketing Manager, is now VP for DIY and Wholesale.

Barry Jardim moves to the newly created IoT and AV Division where he joins Donovan James (Eliot Residential Manager). Barry's new role is that of Eliot Commercial Manager.

Quinton Pillay will move to our Western Cape office in July 2023 to take on the position of Legrand Data Center Solutions, Business Development Manager Projects for the Western Cape.

Lastly, we bid farewell to Lochner Kock who is leaving Legrand to explore the scenes of the French Riviera. We wish Lochner much joy and prosperity for his new ventures.

Taking over Lochner's responsibilities as Business Developer for DIY & Wholesale in the Western Cape is Jayson Gough.

We congratulate everyone on their new roles and wish them much success.



QUINTON PILLAY
- LDCS BUSINESS DEVELOPMENT
MANAGER PROJECTS
- WESTERN CAPE



JAYSON GOUGH
- BUSINESS DEVELOPER
DIY & WHOLESALE



LOCHNER KOCK

Farewell



LEGRAND SOLUTIONS

SERVICES





SERVICES FOR YOUR PROJECTS



Legrand South Africa has entered into a new business model of service level agreements with strategic partners, enabling us to offer direct installation and after sales services.



Working with our partners, we are able to provide in house CAD services for your project needs, as well as ensuring that Legrand products fit the application.



We have qualified C1 and C3 Engineers and Technicians in Cape Town, Johannesburg and Durban for all projects in South Africa but also supporting countries like Botswana, Namibia and Zambia.



Our after sales support system allows for Tier 3 level support on



Dedicated after sales service technicians ensure that the backup power solutions deliver the highest standard of performance and reliability, at minimal cost. Factory trained technicians are capable of dealing with



LEGRAND SOLUTIONS

LEGRAND SOUTH AFRICA SERVICES OFFERING TO MAINTAIN AND OPTIMISE EQUIPMENT

Legrand South Africa has introduced a new services and solutions plan that is tailored to meet exact customer requirements, at the same time ensuring the highest standards in electrical and digital building infrastructure.

The Legrand team understands that dependable power and networking services are critical in many sectors, including data centres, healthcare and hospitality, as well as in commercial and industrial projects.

According to Legrand specialists, it is increasingly important - as South Africa's power crisis deepens and there is a greater need for digital stability - that professionals assist industry, business owners, healthcare institutions and people at home, to continue to function as normally as possible.

Legrand is committed to working closely with customers to ensure sustainability, energy efficiency and optimum performance of equipment for every installation, at all times.

The local operation has entered into service agreements with strategic partners, enabling the team to offer direct installation and after-sales services. Legrand specialists work closely with partners to provide in house CAD services for project requirements, also ensuring that suitable products are selected for every specific installation.

The Legrand team - which comprises highly-skilled engineers and technicians in Cape Town, Johannesburg and Durban - also offers services in Botswana, Namibia and Zambia. A dependable after-sales service, with a dedicated service support line, includes Tier 3 level support to datacentres.

After-sales service technicians and factory trained technicians efficiently handle any repair or breakdown to ensure that backup power solutions deliver the highest standards of performance and reliability, at minimal cost.

Legrand's new services and solutions cover key areas, including transformers, busbars, uninterruptible power supply (UPS) systems and distribution boards.

Services designed to enhance Legrand transformers

(ranging from 650 kVA to 3000 kVA) comprises customised packages to suit specific project requirements. Busbar installation services support Legrand busbars that handle the distribution of power from 63 A to 6 000A. Because it is critical that planning of a busbar system is done correctly from inception, the team assists with design and CAD modelling. This service is supported by onsite engineers who are responsible for installation and commissioning, as well as after sales services.

Legrand also offer comprehensive UPS services that extend from the planning phase





to maintenance. Every part of the process is critical and can lead to catastrophic failure if not done correctly. Consistent services and regular maintenance are essential to ensuring users have power when they need it – especially as scheduled loadshedding and power outages continue to escalate.

Distribution boards form the backbone of every building, by ensuring optimum efficiency and safety in electrical installations.

Legrand services for distribution boards include every aspect, from pre-sales to switch-on of the system and maintenance.

Legrand's environmentally responsible approach to constantly changing project requirements, is enhanced through the introduction of the company's new services and solutions plan. This initiative enhances ongoing technological developments of the company's product portfolio, in terms of energy efficiency, quality power supply, safety and aesthetics.

SERVICES AVAILABLE



TRANSFORMERS

- Various packages are available to suit specific customer requirements
- Transformers included in our service division ranges from 650kVA to 3000kVA



BUSBAR

- Busbar installation services available ranging from 63A to 6000A



UPS

- Comprehensive UPS services available, ranging from planning phase to maintenance



DISTRIBUTION BOARDS

- Services for Distribution Boards from pre-sales to switch on and maintenance.



LINKEO DATA CENTER PDUS

Linkeo Data Center PDUs provide extensive features tailored to the needs of the ever-increasing requirements of data centers. Legrand delivers user value at a competitive cost, facilitating deployment and daily management while improving reliability.



WIRELESS SENSORS TO MONITOR ENVIRONMENTAL RISKS

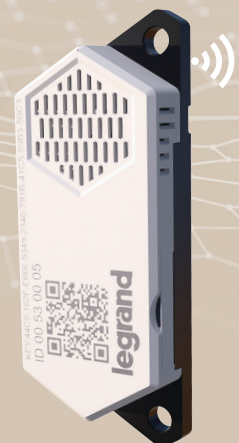



Offering choices from Basic to Switched solutions, this PDU line has been carefully designed to adapt to the diversity of our customers' configurations. Developed on a common platform, it provides solutions that fit your current needs and expectations, while anticipating for maintenance as well as future scaling and upgrades.

When it comes to delivering performance, Linkeo PDUs have been designed for digital excellence. Taking into account the daily challenges encountered in data centers, the range intends to facilitate deployment and maintenance, improve uptime and to provide accurate monitoring, while reducing human error hazards.

Offering expanding functions from standard Metered and Switched intelligent versions, based on a DCIM Agnostic and Open API platform, each power configuration can be acquired with only the BASE, or with the NODE, IP controller mounted for extra connectivity. A Standard PDU portfolio is available with both BASE-only and BASE+NODE configurations.

Flexible deployment applications allow various deployment methods to accommodate different data center environments and constraints. To optimize your IT deployments, the most innovative method is the RS485 cascading. It reduces both your CAPEX, by cutting down the number of IP controllers needed, and your OPEX, by diminishing your production costs (fewer ethernet switch ports). Deployment configurations include RS485 Modbus cascading, USB cascading or standalone.

Facilitating deployment and maintenance

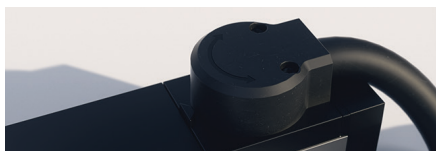

330° rotating input cord



Hot swappable controller architectures



High-density outlet modules

Reducing human error



Cord locking system

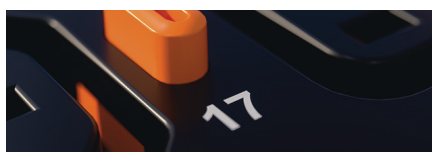

Numbered outlets



PDU Colour-Coding

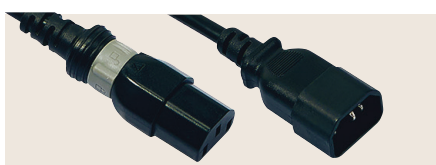

Power cords with server side locking



LEGRAND SOLUTIONS

LINKEO DATA CENTER PDUS

The ergonomic design offers easy rack installation, control and monitoring. Our wireless sensors are easy to fix in your racks, collecting data on environmental risk factors that have an impact on uptime, performance and cost. Up to 8 sensors can be paired per PDU, whether it is a Node PDU or a Base PDU, and uses Zigbee technology natively imbedded in both units. Temperature, humidity and door open and close sensors allows effective monitoring of equipment.

WIRELESS SENSORS TO MONITOR ENVIRONMENTAL RISKS

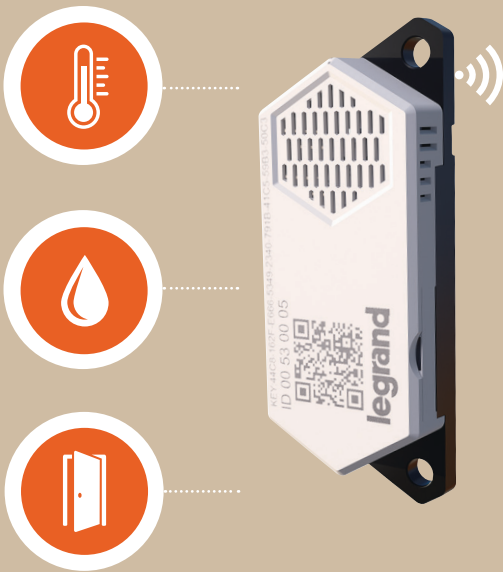

The platform used for Linkeo Data Center PDUs is a combination of hardware and software technologies benefiting from Raritan's* long standing experience in the field. It helps to maximize data center efficiency by delivering security, advanced alerting, intelligence, and visibility into your power chain. Best-in-class in cybersecurity, it has been tested internally and by third parties according to stringent compliance audits.

“The Linkeo Data Center PDU platform meets your power distribution needs worldwide. Four types are available: Basic, Basic with Local Metering, Intelligent Metered and Intelligent Switched. Regardless of geographical area, all delivery models are consistent, and physical specifications comply with IEC standards.”

The Linkeo Data Center PDU platform meets your power distribution needs worldwide. Four types are available: Basic, Basic with Local Metering, Intelligent Metered and Intelligent Switched. Regardless of geographical area, all delivery models are consistent, and physical specifications comply with IEC standards.

Considering its worldwide reach, and in particular, our local sales and technical support teams, Legrand, with its integrated solutions offering, is here to assist you with your data center design and deployment. Linkeo Data Center PDUs have integration capabilities in Legrand Group rack offerings.

With award-winning solutions from strong data center players like Borri, Minkels, Modulan, Raritan, Server Technology, Starline and Zucchini, you benefit from optimal uptime of mission-critical operations. Our team of local specialists design and build innovative solutions including enclosures, cooling, power, structured cabling and access management to meet your unique requirements.

Contact our local team for assistance on your next project: quinton.pillay@legrand.com



EXCITING NEW ADDITIONS TO THE ARTEOR RANGE

ONE MODULE USB



Hailing the arrival of the new Arteor™ one module USB chargers.

The new USB chargers respond to the growing need for increased power delivery for today's demanding devices whilst still delivering the much appreciated aesthetic appeal of the Arteor range.

The range offers the possibility of fast charging with the new USB Type-C 20W charger.

Thanks to the compact mechanism, and the mix of Type A and/or Type C 15W sockets, you can charge according to your needs and evolution of your devices.

FLUSH MOUNT SOCKET

Another much anticipated addition to the Arteor™ range are the new 164-1 flush sockets.

This new addition aims to satisfy the aesthetic requirements of installation within cluster or pop-up box solutions - so no more problems of raised sockets in pop boxes or clusters.

Please refer to SANS 10142 wiring code for wiring configurations for multiple sockets.

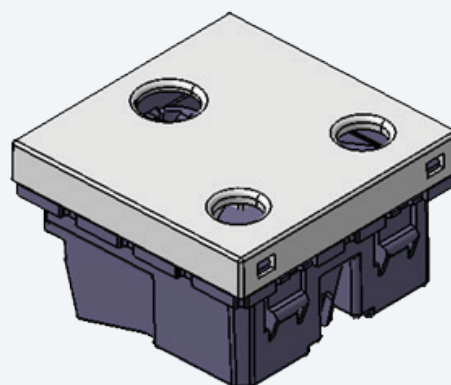



DISTRIBUTORS & RESELLERS

OS
TE
E
L
E



Iletco's spacious showroom is not only aesthetically appealing, it also showcases an extensive range of electrical solutions



DISTRIBUTORS & RESELLERS



Arteor with Netatmo presentation day at Iletco - 8th February 2023

Iletco Zambia is a leading distributor of Legrand products in Zambia. The company has established a reputation for providing high-quality electrical solutions to individuals and businesses across the country.

As a distributor of Legrand products, Iletco Zambia offers a wide range of electrical equipment and systems including switches and sockets, lighting and energy management solutions, wiring accessories, and cable management solutions. The company's product range is designed to meet the diverse needs of its customers, from small domestic installations to large commercial projects.

In addition to its extensive product range, Iletco Zambia is also committed to providing excellent customer service. The company's team of experienced and knowledgeable staff are always on hand to offer expert advice and guidance on the best products to meet each customer's specific requirements. This dedication to customer satisfaction has helped Iletco Zambia build a loyal customer base that continues to grow as the company expands its reach across Zambia.

One of the key advantages of choosing Iletco Zambia as a distributor for Legrand products is the company's extensive network of distribution channels. This means that customers can access quality Legrand products regardless of their location, ensuring that their electrical needs are met with ease.

In conclusion, Iletco Zambia is a reputable and reliable distributor of Legrand products in Zambia. The company's commitment to providing high-quality electrical solutions, coupled with its extensive product range and excellent customer service, make it an ideal partner for individuals and businesses seeking quality solutions for their electrical needs. Whether you are looking for switches and sockets for your home, or energy management solutions for your business, Iletco Zambia has the expertise and experience to help you find the perfect solution.



Cronlec Golf Day



Marius Pretorius winner of an Arteor with Netatmo Starter Kit in the lucky draw held at the Cronlec Golf Day



PHOTO WALL



Our brand new interactive IP Door Entry Display in our Johannesburg Showroom



The Legrand South Africa Office and warehouse Teams